

# MENIIT

NEET | IIT-JEE | FOUNDATION

Corporate Office: 44-A/1, Kalu Sarai, New Delhi 110016 | Web: [www.meniit.com](http://www.meniit.com)

## JEE MAINS-2015

### 11-04-2015 (Online-2)

#### IMPORTANT INSTRUCTIONS

1. The test is of **3** hours duration.
2. The Test Booklet consists of **90** questions. The maximum marks are **360**.
3. There are **three** parts in the question paper A, B, C consisting of **Physics, Chemistry and Mathematics** having 30 questions in each part of equal weightage. Each question is allotted **4 (four)** marks for each correct response.
4. Candidates will be awarded marks as stated above in instruction No.3 for correct response of each question. 1/4 (one fourth) marks will be deducted for indicating incorrect response of each question. No deduction from the total score will be made if no response is indicated for an item in the answer sheet.
5. There is only one correct response for each question. Filling up more than one response in each question will be treated as wrong response and marks for wrong response will be deducted accordingly as per instruction 4 above.

## PART-A-PHYSICS

1. A particle is moving in a circle of radius  $r$  under the action of a force  $F = \alpha r^2$  which is directed towards centre of the circle. Total mechanical energy (kinetic energy + potential energy) of the particle is (take potential energy = 0 for  $r = 0$ ) :

(1)  $\frac{4}{3}\alpha r^3$                       (2\*)  $\frac{5}{6}\alpha r^3$                       (3)  $\alpha r^3$                       (4)  $\frac{1}{2}\alpha r^3$

Sol.  $dU = F \cdot dr$

$$U = \int_0^r \alpha r^2 dr = \frac{\alpha r^3}{3}$$

$$\frac{mv^2}{r} = \alpha r^2$$

$$m^2 v^2 = m \alpha r^3$$

$$2m(\text{KE}) = \frac{1}{2}\alpha r^3$$

$$\text{Total E} = \frac{\alpha r^3}{3} + \frac{\alpha r^3}{2} = \frac{5}{3}\alpha r^3$$

2. A beaker contains a fluid of density  $\rho$  kg/m<sup>3</sup>, specific heat  $S$  J/kg°C and viscosity  $\eta$ . The beaker is filled up to height  $h$ . To estimate the rate of heat transfer per unit area ( $Q/A$ ) by convection when beaker is put on a hot plate, a student proposes that it should depend on  $\eta$ ,  $\left(\frac{S\Delta\theta}{h}\right)$  and  $\left(\frac{1}{\rho g}\right)$  when  $\Delta\theta$  (in °C) is difference in the temperature between the bottom and top of the fluid. In that situation the correct option for ( $Q/A$ ) is :

(1)  $\eta \left(\frac{S\Delta\theta}{h}\right) \left(\frac{1}{\rho g}\right)$                       (2\*)  $\eta \frac{S\Delta\theta}{h}$                       (3)  $\left(\frac{S\Delta\theta}{\eta h}\right) \left(\frac{1}{\rho g}\right)$                       (4)  $\frac{S\Delta\theta}{\eta h}$

Sol.  $\frac{Q}{A} = \eta^a \left(\frac{S\Delta\theta}{h}\right)^b \left(\frac{1}{\rho g}\right)^c$

$$MT^{-3} = [ML^{-1}T^{-1}]^a [LT^{-2}]^b [M^{-1}L^2T^2]^c$$

$$MT^{-3} = [M^{a-c}L^{-a+b+2c}T^{-a-2b+2c}]$$

Salving

$$\frac{Q}{A} = \eta \frac{S\Delta\theta}{h}$$

Option (4)

3. A wire of length  $L$  ( $= 20$  cm) is bent into a semi-circular arc. If the two equal halves of the arc, were each to be uniformly charged with charges  $\pm Q$ , [ $Q = 10^3 \epsilon_0$  Coulomb where  $\epsilon_0$  is the permittivity (in SI unit) of free space] the net electric field at the centre  $O$  of the semi-circular arc would be :

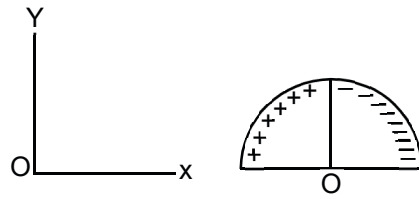

- (1)  $(50 \times 10^3 \text{ N/C}) \hat{j}$       (2)  $(25 \times 10^3 \text{ N/C}) \hat{j}$       (3)  $(50 \times 10^3 \text{ N/C}) \hat{i}$       (4\*)  $(25 \times 10^3 \text{ N/C}) \hat{i}$

Sol.  $E = \frac{2K\lambda}{r}$

$$E = \frac{2K \left( \frac{2Q}{\pi r} \right)}{r} = \frac{4KQ}{\pi r^2} = \frac{4KQ\pi^2}{\pi L^2} = \frac{4\pi KQ}{L^2} = 25 \times 10^3 \text{ N/C} \hat{i}$$

4. Two long straight parallel wires carrying (adjustable) currents  $I_1$  and  $I_2$ , are kept at a distance  $d$  apart. If the force 'F' between the two wires is taken as 'positive' when the wires repel each other and 'negative' when the wires attract each other, the graph showing the dependence of 'F', on the product  $I_1 I_2$ , would be :

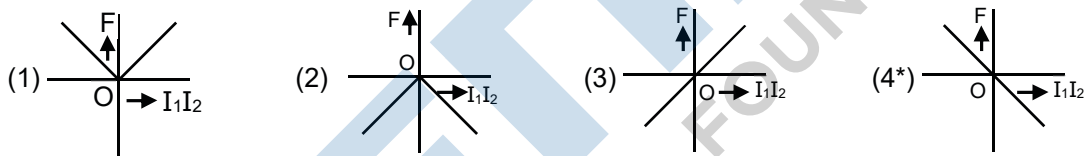

Sol.

$I_1 I_2 = \text{Positive}$   
(attract)  $F = \text{Negative}$

$I_1 I_2 = \text{Negative}$   
(repel)  $F = \text{Positive}$

5. In the electric network shown, when no current flows through the  $4\Omega$  resistor in the arm EB, the potential difference between the points A and D will be :

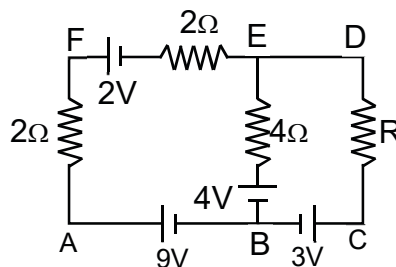

- (1\*)  $5 \text{ V}$       (2)  $6 \text{ V}$       (3)  $4 \text{ V}$       (4)  $3 \text{ V}$

Sol. Let  $V_D = 0 \text{ V}$

$V_E = 0V$   
 $V_B = -4V$   
 $V_A = 5V$   
 $V_A - V_D = 5V$

6. Using equipartition of energy, the specific heat (in  $J\ kg^{-1}K^{-1}$ ) of aluminium at room temperature can be estimated to be (atomic weight of aluminium = 27)

- (1) 925                      (2) 1850                      (3\*) 25                      (4) 410

Sol. Using equipartition of energy

$$\frac{6}{2}KT = mCT$$

$$C = \frac{3 \times 1.38 \times 10^{-23} \times 6.02 \times 10^{23}}{27 \times 10^{-3}}$$

$$= 925\ J/kgK$$

7. The value of the resistor  $R_s$ , needed in the dc voltage regulator circuit shown here, equals :

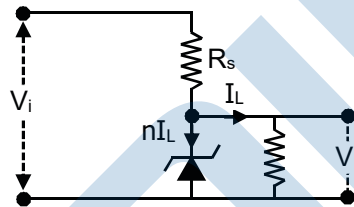

- (1\*)  $(V_i - V_L)/(n + 1)I_L$     (2)  $(V_i + V_L)/nI_L$     (3)  $(V_i + V_L)/(n + 1)I_L$     (4)  $(V_i - V_L)/nI_L$

Sol. Voltage on resistor  $R_s = V_i - V_L$

$$(I_L + nI_L) R_s = V_i - V_L$$

$$R_s = \frac{V_i - V_L}{(n + 1)I_L}$$

8. For the LCR circuit, shown here, the current is observed to lead the applied voltage. An additional capacitor  $C'$ , when joined with the capacitor  $C$  present in the circuit, makes the power factor of the circuit unity. The capacitor  $C'$ , must have been connected in :

- (1) series with  $C$  and has a magnitude  $\frac{1 - \omega^2 LC}{\omega^2 L}$

- (2) series with  $C$  and has a magnitude  $\frac{C}{\omega^2 LC - 1}$

- (3\*) parallel with  $C$  has a magnitude  $\frac{1 - \omega^2 LC}{\omega^2 L}$

- (4) parallel with  $C$  and has a magnitude  $\frac{C}{(\omega^2 LC - 1)}$

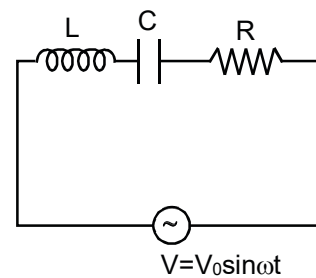

Sol. 
$$\cos \phi = \frac{R}{\sqrt{R^2 + \left[ \omega L - \frac{1}{\omega(C + C')} \right]^2}} = 1$$

$$\omega L = \frac{1}{\omega(C + C')}$$

$$C' = \frac{1 - \omega^2 LC}{\omega^2 L}$$

9. An electric field  $\vec{E} = (25\hat{i} + 30\hat{j})\text{NC}^{-1}$  exists in a region of space. If the potential at the origin is taken to be zero then the potential at  $x = 2, y = 2$  m is :

- (1) - 120 J                      (2) - 130 J                      (3\*) - 110 J                      (4) - 140 J

Sol.  $\int_0^V dV = - \int_0^{2,2} (25dx + 30dy)$

$V = - 110$  volt.

10. In figure is shown a system of four capacitors connected across a 10 V battery. Charge that will flow from switch S when it is closed is :

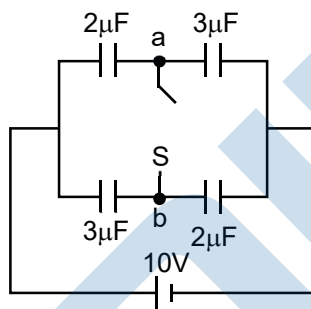

- (1) 5 μC from a to b                      (2) zero                      (3\*) 5 μC from b to a                      (4) 20 μC from a to b

Sol.

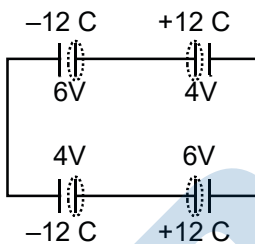

After switch is closed.

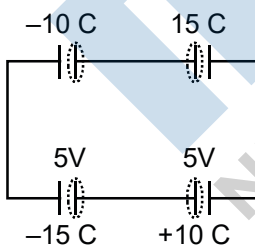

11. A large number ( $n$ ) of identical beads, each of mass  $m$  and radius  $r$  are strung on a thin smooth rigid horizontal rod of length  $L$  ( $L \gg r$ ) and are at rest at random positions. The rod is mounted between two rigid supports (see figure). If one of the beads is now given a speed  $v$ , the average force experienced by each support after a long time is (assume all collisions are elastic) :

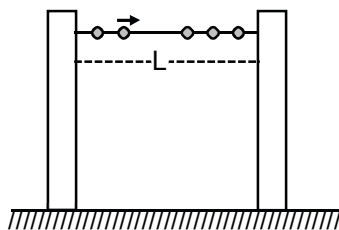

- (1)  $\frac{mv^2}{L - nr}$       (2)  $\frac{mv^2}{2(L - nr)}$       (3\*)  $\frac{mv^2}{L - 2nr}$       (4) zero

Sol. Space between the supports for motion of beads is  $L - 2nr$

$$F = \frac{2mV}{\frac{2(L - 2nr)}{v}} = \frac{mV^2}{L - 2nr}$$

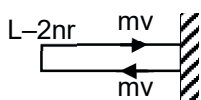

12. A particle of mass 2 kg is on a smooth horizontal table and moves in a circular path of radius 0.6 m. The height of the table from the ground is 0.8 m. If the angular speed of the particle is  $12 \text{ rad s}^{-1}$ , the magnitude of its angular momentum about a point on the ground right under the centre of the circle is :
- (1)  $20.16 \text{ kg m}^2\text{s}^{-1}$       (2)  $11.52 \text{ kg m}^2 \text{ s}^{-1}$       (3)  $8.64 \text{ kg m}^2\text{s}^{-1}$       (4\*)  $14.4 \text{ kg m}^2\text{s}^{-1}$

Sol.  $L_0 = mvr \sin 90^\circ$

$$= m(0.6\omega)r$$

$$= 2 \times 0.6 \times 12 \times 1$$

$$= 14.4 \text{ kgm}^2/\text{s}$$

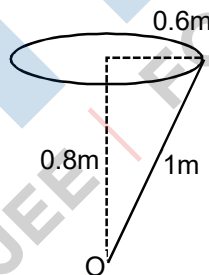

13. A cylindrical block of wood (density =  $650 \text{ kg m}^{-3}$ ), of base area  $30 \text{ cm}^2$  and height 54 cm, floats in a liquid of density  $900 \text{ kg m}^{-3}$ . The block is depressed slightly and then released. The time period of the resulting oscillation of the block would be equal to that of a simple pendulum of length (nearly) :
- (1\*) 39 cm      (2) 65 cm      (3) 26 cm      (4) 52 cm

Sol.  $mg = F_B$

$h$  = Length of block immersed in water

$$650 \times A \times 54 \times 10^{-2}g = 900 \times A \times hg$$

$$h = 0.39m = 39 \text{ cm.}$$

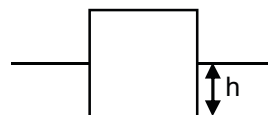

14. The de-Broglie wavelength associated with the electron in the  $n = 4$  level is :
- (1) two times the de-Broglie wavelength of the electron in the ground state  
 (2) half of the de-Broglie wavelength of the electron in the ground state  
 (3\*) four times the de-Broglie wavelength of the electron in the ground state  
 (4)  $1/4^{\text{th}}$  of the de-Broglie wavelength of the electron in the ground state

**Sol.** De-Broglie wavelength of electron

$$\lambda = \frac{h}{mV} \qquad V \propto \frac{1}{n}$$

$$\lambda \propto n$$

$$\lambda_4 = 4\lambda_1$$

**15.** A wire carrying current  $I$  is tied between points  $P$  and  $Q$  and is in the shape of a circular arch of radius  $R$  due to a uniform magnetic field  $B$  (perpendicular to the plane of the paper, shown by xxx) in the vicinity of the wire. If the wire subtends an angle  $2\theta_0$  at the centre of the circle (of which it forms an arch) then the tension in the wire is :

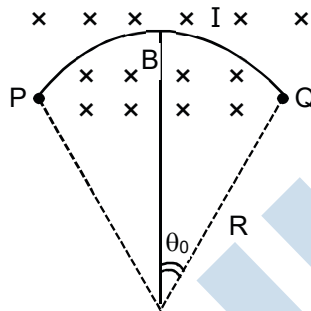

- (1\*)  $IBR$                       (2)  $\frac{IBR\theta_0}{\sin\theta_0}$                       (3)  $\frac{IBR}{\sin\theta_0}$                       (4)  $\frac{IBR}{2\sin\theta_0}$

**Sol.** For small arc length  $2T \sin \theta = BIR \ 2\theta$   
 $T = BIR$

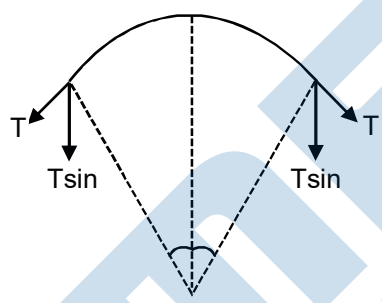

**16.** Unpolarized light of intensity  $I_0$  is incident on surface of a block of glass at Brewster's angle. In that case, which one of the following statement is true ?

(1) reflected light is partially polarized with intensity  $I_0/2$   
 (2\*) reflected light is completely polarized with intensity less than  $I_0/2$ .  
 (3) transmitted light is partially polarized with intensity  $I_0/2$   
 (4) transmitted light is completely polarized with intensity less than  $I_0/2$

**Sol.** When unpolarised light is incident at Brewster's angle then the intensity of the reflected light is less than half of the incident light.

17. Which of the following most closely depicts the correct variation of the gravitation potential  $V(r)$  due to a large planet of radius  $R$  and uniform mass density ? (figures are not drawn to scale)

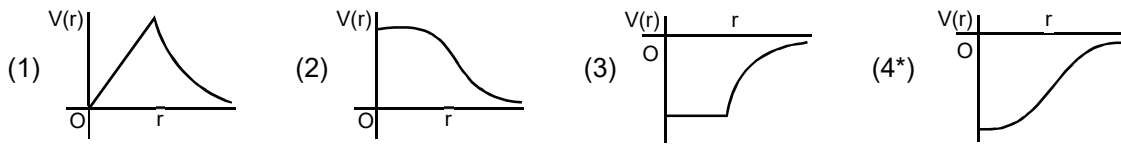

Sol.  $V = -\frac{GM}{2R^3}(3R^2 - r^2)$

18. A short bar magnet is placed in the magnetic meridian of the earth with north pole pointing north. Neutral points are found at a distance of 30 cm from the magnet on the East - West line, drawn through the middle point of the magnet. The magnetic moment of the magnet in  $\text{Am}^2$  is close to :

(Given  $\frac{\mu_0}{4\pi} = 10^{-7}$  in SI units and

$B_H$  = Horizontal component of earth's magnetic field =  $3.6 \times 10^{-5}$  Tesla)

- (1) 4.9                                      (2) 14.6                                      (3\*) 9.7                                      (4) 19.4

Sol.  $\frac{\mu_0}{4\pi} \frac{M}{r^3} = 3.6 \times 10^{-5}$

$M = \frac{3.6 \times 10^{-5}}{10^{-7}} (0.3)^3$

$M = 9.7 \text{ Am}^2$

19. The AC voltage across a resistance can be measured using a :
- (1) hot wire voltmeter                                      (2) moving magnet galvanometer  
 (3\*) moving coil galvanometer                                      (4) potentiometer

Sol. A moving coil galvanometer is used to measure AC voltage.

20. A thin convex lens of focal length 'f' is put on a plane mirror as shown in the figure. When an object is kept at a distance 'a' from the lens - mirror combination, its image is formed at a distance  $\frac{a}{3}$  in front of the combination. The value of 'a' is :

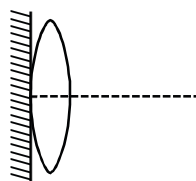

- (1\*)  $2f$                                       (2)  $\frac{3}{2}f$                                       (3)  $3f$                                       (4)  $f$

Sol. Lens :

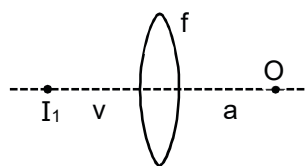

$\frac{1}{v} - \frac{1}{(-a)} = \frac{1}{f}$



$$\frac{1}{v} = \frac{1}{f} - \frac{1}{a}$$

Mirror : Forms image at equal distance from mirror

lens :

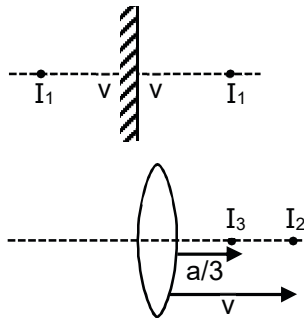

$$\frac{3}{a} - \frac{1}{v} = \frac{1}{f}$$

$$\frac{3}{a} - \frac{1}{f} + \frac{1}{a} = \frac{1}{f}$$

$$a = 2f$$

21. In a Young's double slit experiment with light of wavelength  $\lambda$  the separation of slits is  $d$  and distance of screen is  $D$  such that  $D \gg d \gg \lambda$  If the Fringe width is  $\beta$ , the distance from point of maximum intensity to the point where intensity falls to half of maximum intensity on either side is :

- (1)  $\frac{\beta}{2}$                       (2)  $\frac{\beta}{6}$                       (3\*)  $\frac{\beta}{4}$                       (4)  $\frac{\beta}{3}$

Sol.  $2I_0 = 4I_0 \cos^2\left(\frac{\Delta\phi}{2}\right)$

$$\Delta\phi = \frac{\pi}{2}$$

$$\Delta\phi = \frac{2\pi}{\lambda} \Delta x$$

$$\Delta x = \frac{\lambda}{4}$$

$$\frac{dy}{D} = \frac{\lambda}{4} \dots(i)$$

$$\frac{\lambda D}{d} = \beta \dots(ii)$$

Multiply both  $y = \frac{\beta}{4}$

22. A 2V battery is connected across AB as shown in the figure. The value of the current supplied by the battery when in one case battery's positive terminal is connected to A and in other case when positive terminal of battery is connected to B will respectively be :

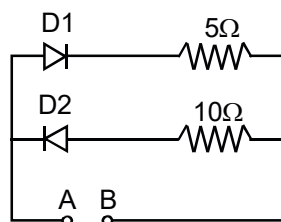

- (1\*) 0.4 A and 0.2 A      (2) 0.2 A and 0.1 A      (3) 0.1 A and 0.2 A      (4) 0.2 A and 0.4 A

**Sol.** When positive terminal connected to A then D1 is forward biased

$$I = \frac{2}{5} = 0.4A$$

When positive terminal connected to B then D2 is forward biased

$$I = \frac{2}{10} = 0.2A$$

**23.** A uniform thin rod AB of length L has linear mass density  $\mu(x) = a + \frac{bx}{L}$ , where x is measured from A. If the CM of the rod lies at a distance of  $\left(\frac{7}{12}L\right)$  from A, then a and b are related as :

- (1)  $3a = 2b$                       (2)  $a = b$                       (3\*)  $2a = b$                       (4)  $a = 2b$

**Sol.** 
$$x_{cm} = \frac{\int_0^L (ax + \frac{bx^2}{L}) dx}{\int_0^L (a + \frac{bx}{L}) dx}$$

$$\frac{7L}{12} = \frac{\frac{a}{2} + \frac{b}{3}}{a + \frac{b}{2}}$$

$$b = 2a$$

**24.** A vector  $\vec{A}$  is rotated by a small angle  $\Delta\theta$  radians ( $\Delta\theta \ll 1$ ) to get a new vector  $\vec{B}$ . In that case  $|\vec{B} - \vec{A}|$  is :

- (1\*)  $|\vec{A}| \Delta\theta$                       (2)  $|\vec{A}| \left(1 - \frac{\Delta\theta^2}{2}\right)$                       (3) 0                      (4)  $|\vec{B}| \Delta\theta - |\vec{A}|$

**Sol.** Arc length = Radius  $\times$  Angle

$$|\vec{B} - \vec{A}| = |\vec{A}| \Delta\theta$$

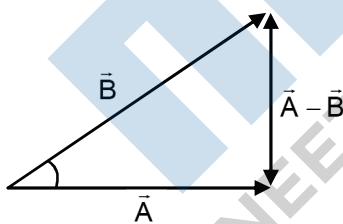

**25.** If electronic charge e, electron mass m, speed of light in vacuum c and Planck's constant h are taken as fundamental quantities, the permeability of vacuum  $\mu_0$  can be expressed in units of :

- (1\*)  $\left(\frac{h}{ce^2}\right)$                       (2)  $\left(\frac{mc^2}{he^2}\right)$                       (3)  $\left(\frac{h}{me^2}\right)$                       (4)  $\left(\frac{hc}{me^2}\right)$

**Sol.**  $\mu_0 = ke^a m^b c^c h^d$

$$[MLT^{-2}A^{-2}] = [AT]^a [M]^b [LT^{-1}]^c [ML^2T^{-1}]^d$$

$$= [M^{b+d} L^{c+2d} T^{a-c-d} A^a]$$

Comparing  $a = -2$

$$\begin{aligned} b + d &= 1 \\ c + 2d &= 1 \\ a - c - d &= -2 \end{aligned}$$

Solving  $a = -2, b = 0, c = -1, d = 1$

$$[\mu_0] = \left[ \frac{h}{ce^2} \right]$$

26. Let  $N_\beta$  be the number of  $\beta$  particles emitted by 1 gram of  $\text{Na}^{24}$  radioactive nuclei (half life = 15 hrs) in 7.5 hours,  $N_\beta$  is close to (Avogadro number =  $6.023 \times 10^{23}$  /g. mole)
- (1\*)  $7.5 \times 10^{21}$       (2)  $6.2 \times 10^{21}$       (3)  $1.25 \times 10^{22}$       (4)  $1.75 \times 10^{22}$

Sol.  $N_\beta = N_0 = (1 - e^{-\lambda t})$

$$N_\beta = \frac{6.023 \times 10^{23}}{24} \left[ 1 - e^{-\frac{\ln 2}{15} \times 7.5} \right]$$

$$N_\beta = 7.4 \times 10^{21}$$

27. An experiment takes 10 minutes to raise the temperature of water in a container from  $0^\circ\text{C}$  to  $100^\circ\text{C}$  and another 55 minutes to convert it totally into steam by a heater supplying heat at a uniform rate. Neglecting the specific heat of the container and taking specific heat of water to be  $1 \text{ cal/g } ^\circ\text{C}$ , the heat of vaporization according to this experiment will come out to be :
- (1\*)  $550 \text{ cal/g}$       (2)  $560 \text{ cal/g}$       (3)  $540 \text{ cal/g}$       (4)  $530 \text{ cal/g}$

Sol.  $Pt = mC\Delta T$

$$P \times 10 \times 60 = mC 100$$

$$P \times 55 \times 60 = mL$$

$$\frac{10}{55} = \frac{C \times 60}{L}$$

$$L = 550 \text{ cal./g.}$$

28. A source of sound emits sound waves at frequency  $f_0$ . It is moving towards an observer with fixed speed  $v_s$  ( $v_s < v$ , where  $v$  is the speed of sound in air). If the observer were to move towards the source with speed  $v_0$ , one of the following two graphs (A and B) will give the correct variation of the frequency  $f$  heard by the observer as  $v_0$  is changed. The variation of  $f$  with  $v_0$  is given correctly by :

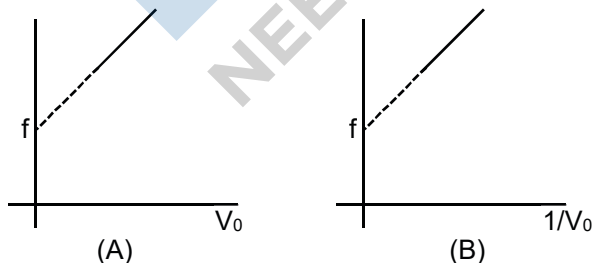

(1) graph A with slope =  $\frac{f_0}{(v + v_s)}$

(2) graph B with slope =  $\frac{f_0}{(v + v_s)}$

(3\*) graph A with slope =  $\frac{f_0}{(v - v_s)}$

(4) graph B with slope =  $\frac{f_0}{(v - v_s)}$

Sol.  $f = \frac{V + V_0}{V - V_s} f_0$

$$f = \left( \frac{f_0}{V - V_s} \right) V_0 + \frac{V f_0}{V - V_s}$$

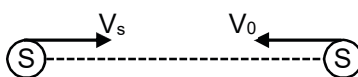

$$\text{slope} = \frac{f_0}{V - V_s}$$

29. A pendulum with time period of 1s is losing energy due to damping. At certain time its energy is 45J. If after completing 15 oscillations, its energy has become 15J, its damping constant (in s<sup>-1</sup>) is :

- (1)  $\frac{1}{2}$                       (2) 2                      (3\*)  $\frac{1}{15} \ln 3$                       (4)  $\frac{1}{30} \ln 3$

Sol.  $A = A_0 e^{-\frac{bt}{2m}}$

$$E = \frac{1}{2} K A_0^2 e^{-\frac{b15}{m}}$$

$$\frac{1}{3} = e^{-\frac{b15}{m}}$$

$$\frac{b}{m} = \frac{1}{15} \ln 3$$

30. For plane electromagnetic waves propagating in the z direction, which one of the following combination gives the correct possible direction for  $\vec{E}$  and  $\vec{B}$  field respectively ?

- (1)  $(2\hat{i} + 3\hat{j})$  and  $(\hat{i} + 2\hat{j})$                       (2\*)  $(-2\hat{i} - 3\hat{j})$  and  $(3\hat{i} - 2\hat{j})$   
 (3)  $(3\hat{i} + 4\hat{j})$  and  $(4\hat{i} - 3\hat{j})$                       (4)  $(\hat{i} + 2\hat{j})$  and  $(2\hat{i} - \hat{j})$

Sol.  $\vec{E} \cdot \vec{B} = 0$

$$\therefore [\vec{E} \perp \vec{B}]$$

options B, C, D are possible

$\vec{E} \times \vec{B}$  should be along Z direction

$$(-2\hat{j} - 3\hat{j}) \times (3\hat{i} - 2\hat{j}) = 5\hat{k}$$

## PART-B-CHEMISTRY

31. Chlorine water on standing loses its colour and forms :  
 (1\*) HCl and HOCl      (2) HCl only      (3) HOCl and HOCl<sub>2</sub>      (4) HCl and HClO<sub>2</sub>

Sol.  $\text{Cl}_2 + \text{H}_2\text{O} \rightarrow \text{HCl} + \text{HOCl}$

32. The increase of pressure on ice  $\rightleftharpoons$  water system at constant temperature will lead to :  
 (1\*) a shift of the equilibrium in the forward direction  
 (2) an increase in the Gibbs energy of the system  
 (3) a decrease in the entropy of the system  
 (4) no effect on the equilibrium

Sol. On increasing pressure, reaction shifts in the direction of increasing density. Water has higher density than ice. So reaction shifts in forward direction.

33. Which of the alkaline earth metal halides given below is essentially covalent in nature ?  
 (1) CaCl<sub>2</sub>      (2\*) BeCl<sub>2</sub>      (3) SrCl<sub>2</sub>      (4) MgCl<sub>2</sub>

Sol. Fact

34. Addition of phosphate fertilizers to water bodies causes :  
 (1\*) enhanced growth of algae      (2) increase in amount of dissolved oxygen in water  
 (3) increase in fish population      (4) deposition of calcium phosphate

35. Which of the following compounds has a P–P bond ?  
 (1) H<sub>4</sub>P<sub>2</sub>O<sub>7</sub>      (2) H<sub>4</sub>P<sub>2</sub>O<sub>5</sub>      (3) (HPO<sub>3</sub>)<sub>3</sub>      (4\*) H<sub>4</sub>P<sub>2</sub>O<sub>6</sub>

Sol. H<sub>4</sub>P<sub>2</sub>O<sub>6</sub> has P–P linkage

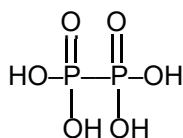

36. Accumulation of which of the following molecules in the muscles occurs as a result of vigorous exercise?  
 (1) Glycogen      (2\*) L-lactic acid      (3) Pyruvic acid      (4) Glucose

Sol. L-lactic acid produced in the process of fermentation in normal metabolism and exercise.

37. In the reaction sequence



- (1) CH<sub>3</sub>–CH<sub>2</sub>–CH<sub>2</sub>–CH<sub>2</sub>–OH      (2\*) CH<sub>3</sub>–CH=CH–CHO  
 (3) CH<sub>3</sub>– $\overset{\text{O}}{\parallel}$ –CH<sub>3</sub>      (4) CH<sub>3</sub>–CH<sub>2</sub>–CH<sub>2</sub>–CH<sub>3</sub>

Sol. It is aldol condensation reaction.

38. For the equilibrium, A(g)  $\rightleftharpoons$  B(g),  $\Delta H$  is – 40kJ/mol. If the ratio of the activation energies of the forward (E<sub>f</sub>) and reverse (E<sub>b</sub>) reactions is  $\frac{2}{3}$  then :

- (1) E<sub>f</sub> = 30 kJ/mol ; E<sub>b</sub> = 70 kJ/mol      (2\*) E<sub>f</sub> = 80 kJ/mol ; E<sub>b</sub> = 120 kJ/mol  
 (3) E<sub>f</sub> = 60 kJ/mol ; E<sub>b</sub> = 100 kJ/mol      (4) E<sub>f</sub> = 70 kJ/mol ; E<sub>b</sub> = 30 kJ/mol

Sol.  $\Delta H = E_{af} - E_{ab}$

$$\Rightarrow -40 = 2x - 3x$$

$$\Rightarrow E_{af} = 80 \text{ kJ/mol}$$

$$E_{ab} = 120 \text{ kJ/mol}$$

39. Match the organic compounds in column-I with the Lassaigne's test results in column-II appropriately :

Column-I	Column-II
(A) Aniline	(i) Red color with $\text{FeCl}_3$
(B) Benzene sulfonic acid	(ii) Violet color with sodium nitroprusside
(C) Thiourea	(iii) Blue color with hot and acidic solution of $\text{FeSO}_4$
(1*) (A)–(iii), (B)–(ii), (C)–(i)	(2) (A)–(ii), (B)–(i), (C)–(iii)
(3) (A)–(iii), (B)–(i), (C)–(ii)	(4) (A)–(ii), (B)–(iii), (C)–(i)

Sol. This is lassaigne test.

40. Which of the following complex ions has electrons that are symmetrically filled in both  $t_{2g}$  and  $e_g$  orbitals?

- (1\*)  $[\text{FeF}_3]^{3-}$       (2)  $[\text{Mn}(\text{CN})_6]^{4-}$       (3)  $[\text{Co}(\text{NH}_3)_6]^{2+}$       (4)  $[\text{CoF}_6]^{3-}$

- Sol. (1)  $\text{Fe}^{3+} (d^5) \rightarrow t_{2g}^3, e_g^2$  (symmetrically filled)  
 (2)  $\text{Mn}^{2+} (d^5) \rightarrow t_{2g}^5, e_g^0$  ( $t_{2g}$  unsymmetrically filled)  
 (3)  $\text{Co}^{3+} (d^6) \rightarrow t_{2g}^4, e_g^2$  (non-symmetrically filled)  
 (4)  $\text{Co}^{2+} (d^7) \rightarrow t_{2g}^6, e_g^1$  (non-symmetrically filled)

41. Which compound exhibits maximum dipole moment among the following ?

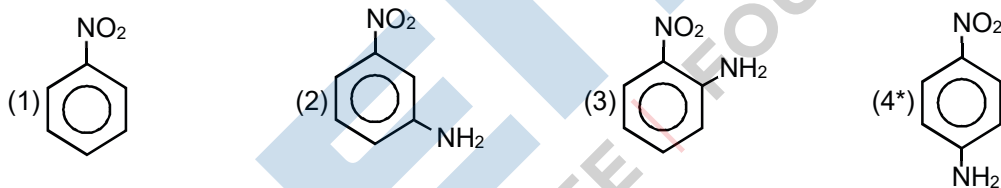

Sol.  is more polar due to linear dipole

42. Which physical property of dihydrogen is wrong ?

- (1) Tasteless gas      (2\*) Non-inflammable gas  
 (3) Odourless gas      (4) Colourless gas

Sol.  $\text{H}_2$  is highly inflammable.

43. A pink coloured salt turns blue on heating. The presence of which cation is most likely ?

- (1)  $\text{Zn}^{2+}$       (2)  $\text{Fe}^{2+}$       (3)  $\text{Cu}^{2+}$       (4\*)  $\text{Co}^{2+}$

Sol.  $\text{Zn}^{2+}$  salts are white usually  $\text{Fe}^{2+}$  salts are rarely pink.  $\text{Cu}^{2+}$  salts are usually blue in hydrated form.  $\text{Co}^{2+}$  is pink in aqueous solution.

44.  $\text{A} + 2\text{B} \rightarrow \text{C}$ , the rate equation for this reaction is given as

$$\text{Rate} = K[A][B].$$

If the concentration of A is kept the same but that of B is doubled what will happen to the rate itself ?

- (1) halved                      (2) quadrupled                      (3\*) doubled                      (4) the same

**Sol.** Rate is first order with respect to B. So it doubles on doubling concentration of B, while keeping concentration of A as same.

**45.** Determination of the molar mass of acetic acid in benzene using freezing point depression is affected by :

- (1) partial ionization                      (2) dissociation                      (3) complex formation                      (4\*) association

**Sol.** Benzene is non-polar solvent.

**46.** Which artificial sweetener contains chlorine ?

- (1\*) Sucralose                      (2) Aspartame                      (3) Alitame                      (4) Saccharin

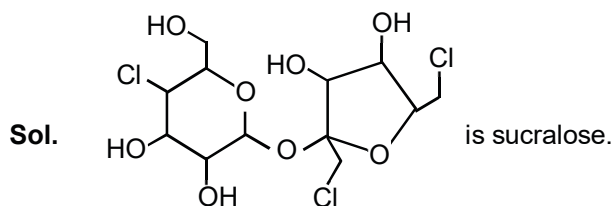

**47.** When concentrated HCl is added to an aqueous solution of  $\text{CoCl}_2$ , its colour changes from reddish pink to deep blue. Which complex ion gives blue colour in this reaction ?

- (1)  $[\text{Co}(\text{H}_2\text{O})_6]^{2+}$                       (2)  $[\text{CoCl}_6]^{3-}$                       (3\*)  $[\text{CoCl}_4]^{2-}$                       (4)  $[\text{CoCl}_6]^{4-}$

**Sol.**  $[\text{CoCl}_4]^{2-}$  is formed which is blue in colour.

**48.** At temperature T, the average kinetic energy of any particle is  $\frac{3}{2} kT$ . The de Broglie wavelength follows the order :

- (1) Visible photon > Thermal neutron > Thermal electron  
 (2\*) Visible photon > Thermal electron > Thermal neutron  
 (3) Thermal proton > Thermal electron > Visible photon  
 (4) Thermal proton > Visible photon > Thermal electron

**Sol.** De-broglie wavelength (for particles) =  $\frac{h}{\sqrt{2mKE}}$

As temperature is same, KE is same. So,  $\lambda \propto \frac{1}{\sqrt{m}}$ .

Hence  $\lambda_{\text{db}}(\text{electron}) > \lambda_{\text{db}}(\text{neutron})$

**49.** Which of the following statements is false ?

- (1)  $\text{CrO}_4^{2-}$  is tetrahedral in shape                      (2\*)  $\text{Na}_2\text{Cr}_2\text{O}_7$  is less soluble than  $\text{K}_2\text{Cr}_2\text{O}_7$   
 (3)  $\text{Cr}_2\text{O}_7^{2-}$  has a Cr–O–Cr bond                      (4)  $\text{Na}_2\text{Cr}_2\text{O}_7$  is a primary standard in volumetry

**Sol.**  $\text{Na}_2\text{C}_2\text{O}_7$  is more soluble than  $\text{K}_2\text{Cr}_2\text{O}_7$ .

**50.** When does a gas deviate the most from its ideal behaviour ?

- (1\*) At high pressure and low temperature      (2) At low pressure and low temperature  
 (3) At low pressure and high temperature      (4) At high pressure and high temperature

**Sol.** At high pressure and low temperature, size of molecules and inter molecular forces cannot be neglected.

**51.** Which of the following pairs of compounds are positional isomers ?

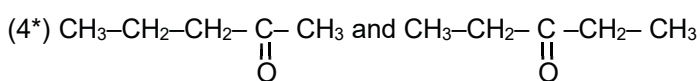
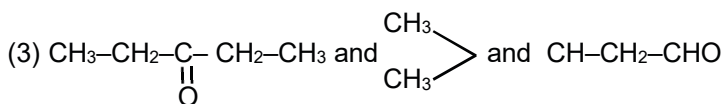
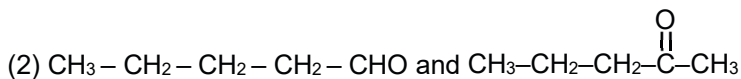
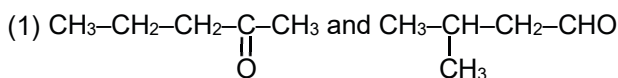

**Sol.** Pentane-2-one and pentan-3-one are positional isomers.

**52.** Choose the incorrect formula out of the four compounds for an element X below :

- (1)  $\text{X}_2(\text{SO}_4)_3$       (2)  $\text{X}_2\text{O}_3$       (3\*)  $\text{X}_2\text{Cl}_3$       (4)  $\text{XPO}_4$

**Sol.** 1,3 and 4 suggests that valency of X is +3.

So, formula of chloride is  $\text{XCl}_3$ .

**53.** The number of structural isomers for  $\text{C}_6\text{H}_{14}$  is :

- (1) 3      (2) 4      (3) 6      (4\*) 5



**54.** At 298 K, the standard reduction potentials are 1.51 V for  $\text{MnO}_4^-|\text{Mn}^{2+}$ , 1.36 V for  $\text{Cl}_2|\text{Cl}^-$ , 1.07 V for

$\text{Br}_2|\text{Br}^-$ , and 0.54 V for  $\text{I}_2|\text{I}^-$ . At pH = 3, permanganate is expected to oxidize :  $\left(\frac{RT}{F} = 0.059\text{V}\right)$

- (1)  $\text{Cl}^-$ ,  $\text{Br}^-$  and  $\text{I}^-$       (2)  $\text{Cl}^-$  and  $\text{Br}^-$       (3)  $\text{I}^-$  only      (4\*)  $\text{Br}^-$  and  $\text{I}^-$

**Sol.**  $\text{MnO}_4^- + 8\text{H}^+ + 5\text{e}^- \longrightarrow \text{Mn}^{2+} + 4\text{H}_2\text{O}$

$$E = 1.51 - \frac{0.059}{5} \log \frac{[\text{Mn}^{2+}]}{[\text{MnO}_4^-][\text{H}^+]^8}$$

Taking  $\text{Mn}^{2+}$  and  $\text{MnO}_4^-$  in standard state i.e. 1 M,

$$E = 1.51 - \frac{0.059}{5} \times 8 \log \frac{1}{[\text{H}^+]^8}$$

$$= 1.51 - \frac{0.059}{5} \times 8 \times 3 = 1.2268\text{V}$$

Hence at this pH,  $\text{MnO}_4^-$  will oxidise only  $\text{Br}^-$  and  $\text{I}^-$  as SRP of  $\text{Cl}_2/\text{Cl}^-$  is 1.36 V which is greater than that for  $\text{MnO}_4^- / \text{Mn}^{2+}$ .



55. Under ambient conditions, which among the following surfactants will form micelles in aqueous solution at lowest molar concentration ?

- (1\*)  $\text{CH}_3(\text{CH}_2)_{15}\text{N}^+(\text{CH}_3)_3\text{Br}^-$                       (2)  $\text{CH}_3(\text{CH}_2)_{11}\text{N}^+(\text{CH}_3)_3\text{Br}^-$   
 (3)  $\text{CH}_3-(\text{CH}_2)_{13}-\text{OSO}_3^-\text{Na}^+$                       (4)  $\text{CH}_3-(\text{CH}_2)_8-\text{COO}^-\text{Na}^+$

Sol. Longer hydrophobic chain, lesser CMC

56. What is the major product expected from the following reaction ?

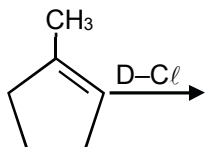

Where D is an isotope of Hydrogen.

- (1\*) (2) (3) (4)

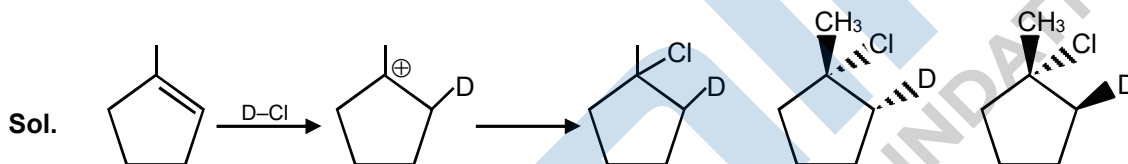

57. Molecular AB has a bond length of 1.617 Å and a dipole moment of 0.38 D. The fractional charge on each atom (absolute magnitude) is : ( $e_0 = 4.802 \times 10^{-10}$  esu)

- (1) 1.0                      (2\*) 0.05                      (3) 0                      (4) 0.5

Sol.  $1\text{D} = 10^{-18}$  esu cm

$$\delta = \frac{0.38 \times 10^{-18}}{1.617 \times 10^{-8} \times 4.8 \times 10^{-10}}$$

$$= 0.0485 \approx 0.05$$

58.  $\text{A} + 2\text{B} + 3\text{C} \rightarrow \text{AB}_2\text{C}_3$

Reaction of 6.0 g of A,  $6.0 \times 10^{23}$  atoms of B, and 0.036 mol of C yields 4.8 g of compound  $\text{AB}_2\text{C}_3$ . If the atomic mass of A and C are 60 and 80 amu, respectively, the atomic mass of B is

(Avogadro no. =  $6 \times 10^{23}$ ) :

- (1\*) 50 amu                      (2) 60 amu                      (3) 70 amu                      (4) 40 amu

Sol.  $n_A = 0.1, n_B = 1, n_C = 0.036$

Limiting reagent = C

$$\Rightarrow n_{\text{AB}_2\text{C}_3} \text{ formed} = \frac{0.036}{3} = 0.012$$

$$\Rightarrow \text{MM}_{(\text{AB}_2\text{C}_3)} \frac{4.8}{0.012} = 400$$

$$\Rightarrow 60 + 2x + 80 \times 3 = 400$$

$$x = 50$$

59. Which one of the following structures represents the neoprene polymer ?

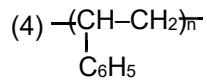
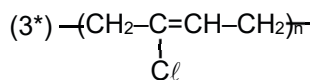
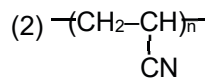
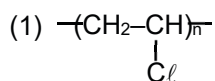

Sol.  $\text{-(CH}_2\text{-C=CH-CH}_2\text{)}_n\text{-}$  is neoprene polymer.  
 $\quad \quad \quad |$   
 $\quad \quad \quad \text{Cl}$

60. Calamine is an ore of :

(1) Iron

(2\*) Zinc

(3) Aluminium

(4) Copper

Sol.  $\text{ZnCO}_3 = \text{calamine.}$

**PART-C-MATHEMATICS**

61. The term independent of x in the binomial expansion of  $\left(1 - \frac{1}{x} + 3x^5\right)\left(2x^2 - \frac{1}{x}\right)^8$  is  
 (1) 496                      (2) -496                      (3\*) 400                      (4) -400

Sol.  $\left(1 - \frac{1}{x} + 3x^5\right) \cdot {}^8C_r (2x^2)^{8-r} \left(-\frac{1}{x}\right)^r$   
 $= {}^8C_r (2x^2)^{8-r} \left(-\frac{1}{x}\right)^r - \frac{1}{x} {}^8C_r (2x^2)^{8-r} \left(-\frac{1}{x}\right)^r + 3x^5 {}^8C_r (2x^2)^{8-r} \left(-\frac{1}{x}\right)^r$   
 $= {}^8C_r 2^{8-r} (-1)^r x^{16-3r} - {}^8C_r 2^{8-r} (-1)^r x^{15-3r} + 3 {}^8C_r 2^{8-r} \left(-\frac{1}{x}\right)^r (-1)^r x^{21-3r}$

for independent term

$16-3r = 0, 15-3r = 0, 21-3r = 0$   
 $r = 5, \quad r = 7$  in III term  
 in II term

$-{}^8C_5(2^3)(-1) - 3 \cdot {}^8C_7 \cdot 2$   
 $= 448 - 6 \times 8 = 448 - 48 = 400$

62. Let PQ be a double ordinate of the parabola,  $y^2 = -4x$ , where P lies in the second quadrant. If R divides PQ in the ratio 2 : 1, then the locus of R is  
 (1\*)  $9y^2 = -4x$               (2)  $3y^2 = -2x$               (3)  $3y^2 = 2x$               (4)  $9y^2 = 4x$

Sol. Let  $P(-at_1^2, 2at_1), Q(-at_1^2, -2at_1), R(h, k)$

$\Rightarrow h = -at_1^2, k = \frac{-2at_1}{3}$   
 $\Rightarrow 9k^2 = -4h \Rightarrow 9y^2 = -4x$

63. If a circle passing through the point  $(-1, 0)$  touches y-axis at  $(0, 2)$ , then the length of the chord of the circle along the x-axis is  
 (1\*) 3                      (2)  $\frac{3}{2}$                       (3)  $\frac{5}{2}$                       (4) 5

Sol.  $(h + 1)^2 + 2^2 = h^2$   
 $\Rightarrow 2h + 5 = 0$

$h = -\frac{5}{2}$

$AB = 2(AM) = 2\sqrt{\frac{25}{4} - 4}$   
 $= 2\left(\frac{3}{2}\right) = 3$

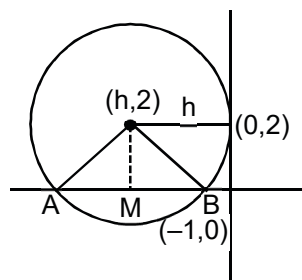

64. If the two roots of the equation  $(a - 1)(x^4 + x^2 + 1) + (a + 1)(x^2 + x + 1)^2 = 0$  are real and distinct, then the set of all values of 'a' is

- (1)  $\left(0, \frac{1}{2}\right)$       (2\*)  $\left(\frac{-1}{2}, 0\right) \cup \left(0, \frac{1}{2}\right)$       (3)  $\left(\frac{-1}{2}, 0\right)$       (4)  $(-\infty, -2) \cup (2, \infty)$

Sol. Equation becomes

$$(a - 1)(x^2 - x + 1) + (a + 1)(x^2 + x + 1) = 0$$

$$ax^2 + x + a = 0$$

for roots to be distinct and real

$$a \neq 0 \text{ and } 1 - 4a^2 > 0$$

$$\Rightarrow 2 \in \left(-\frac{1}{2}, 0\right) \cup \left(0, \frac{1}{2}\right)$$

65. In a parallelogram ABCD,  $|\overline{AB}| = a, |\overline{AD}| = b$  and  $|\overline{AC}| = c$ , then  $\overline{DB} \cdot \overline{AB}$  has the value

- (1\*)  $\frac{1}{4}(a^2 + b^2 - c^2)$       (2)  $\frac{1}{2}(a^2 + b^2 + c^2)$       (3)  $\frac{1}{3}(b^2 + c^2 - a^2)$       (4)  $\frac{1}{4}(a^2 - b^2 + c^2)$

Sol.  $|\overline{AB}| = a$

$$|\overline{AD}| = b$$

$$|\overline{AC}| = c$$

$$\therefore \overline{AB} + \overline{BC} = \overline{AC}$$

$$\overline{AB} + \overline{AD} = \overline{AC}$$

$$|\overline{AB}|^2 + |\overline{AD}|^2 + 2\overline{AB} \cdot \overline{AD} = |\overline{AC}|^2$$

$$\Rightarrow a^2 + b^2 + 2\overline{AB} \cdot (\overline{AB} + \overline{BD}) = c^2$$

$$\Rightarrow 3a^2 + b^2 - c^2 = +2\overline{AB} \cdot \overline{DB}$$

$$\Rightarrow \overline{AB} \cdot \overline{DB} = \frac{1}{2}(3a^2 + b^2 - c^2)$$

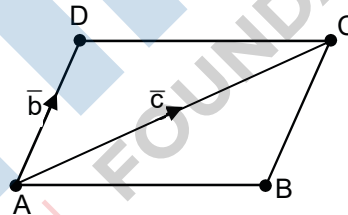

66. Let  $A = \{x_1, x_2, \dots, x_7\}$  and  $B = \{y_1, y_2, y_3\}$  be two sets containing seven and three distinct elements respectively. Then the total number of functions  $f : A \rightarrow B$  that are onto, if there exist exactly three elements  $x$  in  $A$  such that  $f(x) = y_2$ , is equal to

- (1\*)  $14 \cdot {}^7C_3$       (2)  $14 \cdot {}^7C_2$       (3)  $12 \cdot {}^7C_2$       (4)  $16 \cdot {}^7C_3$

Sol. Number of onto function such that exactly three elements in  $x \in A$  such that  $f(x) = \frac{1}{2}$  is equal to

$$= {}^7C_3 \cdot \{2^4 - 2\}$$

$$= 14 \cdot {}^7C_3$$

67. Let  $k$  be a non-zero real number. If  $f(x) = \begin{cases} \frac{(e^x - 1)^2}{\sin\left(\frac{x}{k}\right) \log\left(1 + \frac{x}{4}\right)}, & x \neq 0 \\ 12, & x = 0 \end{cases}$  is a continuous function, then

the value of  $k$  is

- (1\*) 3      (2) 1      (3) 4      (4) 2

**Sol.** 
$$\lim_{x \rightarrow 0} \frac{x^2 \left( \frac{e^x - 1}{x} \right)^2 4k}{\frac{\sin \frac{x}{k}}{\frac{x}{k}} \cdot \frac{\log \left( 1 + \frac{x}{4} \right)}{\frac{x}{4}}}$$

$\Rightarrow 4k = 12 \Rightarrow k = 3$

**68.** If  $\sum_{n=1}^5 \frac{1}{n(n+1)(n+2)(n+3)} = \frac{k}{3}$ , then k is equal to

- (1\*)  $\frac{55}{336}$                       (2)  $\frac{19}{112}$                       (3)  $\frac{17}{105}$                       (4)  $\frac{1}{6}$

**Sol.** 
$$T_r = \frac{1}{3} \left[ \frac{1}{n(n+1)(n+2)} - \frac{1}{(n+1)(n+2)(n+3)} \right]$$

$$\sum_{r=1}^5 T_r = \frac{1}{3} \left[ \frac{1}{6} - \frac{1}{6 \cdot 7 \cdot 8} \right] = \frac{k}{3}$$

$k = \frac{55}{336}$

**69.** If z is a non-real complex number, then the minimum value of  $\frac{\text{Im } z^5}{(\text{Im } z)^5}$  is

- (1\*) -4                      (2) -5                      (3) -1                      (4) -2

**Sol.** Let  $z = re^{i\theta}$

$$\frac{\text{Im } z^5}{(\text{Im } z)^5} = \frac{r^5 (\sin 5\theta)}{r^5 (\sin \theta)^5}$$

$$= \frac{\sin 5\theta}{\sin^5 \theta}$$

$$= \frac{16 \sin^5 \theta - 20 \sin^3 \theta + 5 \sin \theta}{\sin^5 \theta}$$

$$= 5 \operatorname{cosec}^4 \theta - 20 \operatorname{cosec}^2 \theta + 16$$

minimum value of  $\frac{\text{Im } z^5}{(\text{Im } z)^5}$  is -4

**70.** A straight line L through the point (3, -2) is inclined at an angle of 60° to the line  $\sqrt{3}x + y = 1$ . If L also intersects the x-axis, then the equation of L is

- (1)  $\sqrt{3}y - x + 3 + 2\sqrt{3} = 0$                       (2)  $\sqrt{3}y + x - 3 + 2\sqrt{3} = 0$   
 (3)  $y + \sqrt{3}x + 2 - 3\sqrt{3} = 0$                       (4\*)  $y - \sqrt{3}x + 2 + 3\sqrt{3} = 0$

**Sol.** 
$$\tan 60^\circ = \left| \frac{m - (-\sqrt{3})}{1 + (-\sqrt{3}m)} \right|$$

$\Rightarrow m = 0, m = \sqrt{3}$

line  $y + 2 = \sqrt{3}(x - 3)$

$$y - \sqrt{3}x + 2 + 3\sqrt{3} = 0$$

71. Let  $f : (-1, 1) \rightarrow \mathbb{R}$  be a continuous function. If  $\int_0^{\sin x} f(t) dt = \frac{\sqrt{3}x}{2}$ , then  $f\left(\frac{\sqrt{3}}{2}\right)$  is equal to

- (1)  $\frac{\sqrt{3}}{2}$                       (2)  $\sqrt{\frac{3}{2}}$                       (3)  $\frac{1}{2}$                       (4\*)  $\sqrt{3}$

Sol.  $\int_0^{\sin x} f(t) dt = \frac{\sqrt{3}}{2}x$

$$f(\sin x) \cdot \cos x = \frac{\sqrt{3}}{2}$$

put  $x = \frac{\pi}{3}$

$$f\left(\frac{\sqrt{3}}{2}\right) \cdot \frac{1}{2} = \frac{\sqrt{3}}{2}$$

$$f\left(\frac{\sqrt{3}}{2}\right) = \sqrt{3}$$

72. Let 10 vertical poles standing at equal distances on a straight line, subtend the same angle of elevation  $\alpha$  at a point O on this line and all the poles are on the same side of O. If the height of the longest pole is 'h' and the distance of the foot of the smallest pole from O is 'a'; then the distance between two consecutive poles is

- (1\*)  $\frac{h \cos \alpha - a \sin \alpha}{9 \sin \alpha}$       (2)  $\frac{h \sin \alpha + a \cos \alpha}{9 \sin \alpha}$       (3)  $\frac{h \sin \alpha + a \cos \alpha}{9 \sin \alpha}$       (4)  $\frac{h \cos \alpha - a \sin \alpha}{9 \cos \alpha}$

Sol.  $\Delta OA_1B_1, \Delta OA_2B_2, \Delta OA_3B_3, \dots, \Delta OA_{10}B_{10}$  are similar.

$$\Rightarrow \frac{h_1}{a_1} = \frac{h_2}{a_2} = \frac{h_3}{a_3} = \dots = \frac{h_{10}}{a_{10}} = \tan \alpha$$

$$\therefore h_{10} = h = a_{10} \tan \alpha \quad \dots(1)$$

$$\text{and } a_1 = a \Rightarrow h_1 = a \tan \alpha \quad \dots(2)$$

$$\Rightarrow h = (a + 9d) \tan \alpha \text{ where } d \text{ is distance between poles}$$

$$\Rightarrow h = a \tan \alpha + 9d \tan \alpha$$

$$\Rightarrow \frac{h - a \tan \alpha}{9 \tan \alpha}$$

$$\Rightarrow d = \frac{h \cos \alpha - a \sin \alpha}{9 \sin \alpha}$$

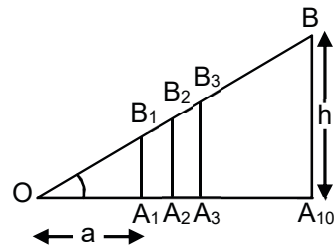

73. The shortest distance between the z-axis and the line  $x + y + 2z - 3 = 0 = 2x + 3y + 4z - 4$ , is

- (1\*) 2                      (2) 1                      (3) 3                      (4) 4

Sol. Equation of z-axis  $\frac{x}{0} = \frac{y}{0} = \frac{z}{1}$

equation of given line

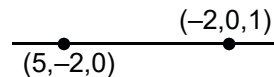

$$\text{S.D.} = \left| \frac{(5i - 2i) \cdot 2j}{2} \right| = 2$$

74. If the mean and the variance of a binomial variate X are 2 and 1 respectively, then the probability that X takes a value greater than or equal to one is

- (1)  $\frac{1}{16}$                       (2)  $\frac{3}{4}$                       (3\*)  $\frac{15}{16}$                       (4)  $\frac{9}{16}$

Sol. mean = np = 2                      ..... (1)

variance npq = 1                      ..... (2)

by (2) and (1)

$$q = \frac{1}{2}$$

$$p = \frac{1}{2}$$

$$\Rightarrow n = 4$$

$$\begin{aligned} P(x \geq 1) &= {}^4C_1 p^1 q^3 + {}^4C_2 p^2 q^2 + {}^4C_3 p^3 q + {}^4C_4 p^4 \\ &= 1 - {}^4C_0 p^0 q^4 \\ &= 1 - \left(\frac{1}{2}\right)^4 = \frac{15}{16} \end{aligned}$$

75. The sum of the 3<sup>rd</sup> and the 4<sup>th</sup> terms of a G.P. is 60 and the product of its first three terms is 1000. If the first term of this G.P. is positive, then its 7<sup>th</sup> term is

- (1) 2430                      (2\*) 320                      (3) 640                      (4) 7290

Sol.  $a(ar)(ar^2) = 1000 \Rightarrow ar = 10$

and  $ar^2 + ar^3 = 60 \Rightarrow ar(r + r^2) = 60$

$$\Rightarrow r^2 + r - 6 = 0$$

$$r = 2, -3$$

$$a = 5, a = -\frac{10}{3} \text{ (reject)}$$

$$T_7 = ar^6 = 5(2)^6 = 5 \times 64 = 320$$

76. Let k and K be the minimum and maximum values of the function  $f(x) = \frac{(1+x)^{0.6}}{1+x^{0.6}}$  in [0, 1] respectively, then the ordered pair (k, K) is equal to

- (1)  $(1, 2^{0.6})$                       (2\*)  $(2^{-0.4}, 1)$                       (3)  $(2^{-0.6}, 1)$                       (4)  $(2^{-0.4}, 2^{0.6})$

Sol.  $f(x) = \frac{(1+x)^{3/5}}{1+x^{3/5}}$

and  $x \in [0, 1]$

$$\Rightarrow f'(x) = \frac{(1+x^{3/5}) \frac{3}{5} (1+x)^{-2/5} - \frac{3}{5} (1+x)^{3/5} (x^{-2/5})}{(1+x^{3/5})^2}$$

$$= \frac{3}{5} [(1+x^{3/5})(1+x)^{-2/5} - (1+x)^{3/5} x^{-2/5}]$$

$$= \frac{3}{5} \left[ \frac{1+x^{3/5}}{(1+x)^{2/5}} - \frac{(1+x)^{3/5}}{x^{2/5}} \right]$$

$$= \frac{x^{2/5} + x - 1 - x}{x^{2/5}(1+x)^{2/5}} < 0$$

$$f(0) = 1 \Rightarrow f(x) \in [2^{-0.4}, 1]$$

$$f(1) = 2^{-0.4}$$

77. If  $\cos \alpha + \cos \beta = \frac{3}{2}$  and  $\sin \alpha + \sin \beta = \frac{1}{2}$  and  $\theta$  is the arithmetic mean of  $\alpha$  and  $\beta$ , then  $\sin 2\theta + \cos$

$2\theta$  is equal to

(1)  $\frac{8}{5}$

(2)  $\frac{4}{5}$

(3)  $\frac{3}{5}$

(4\*)  $\frac{7}{5}$

Sol.  $2\cos \frac{\alpha+\beta}{2} \cos \frac{\alpha-\beta}{2} = \frac{3}{2}$

and  $2\sin \frac{\alpha+\beta}{2} \cos \frac{\alpha-\beta}{2} = \frac{1}{2}$

$$\Rightarrow \tan\left(\frac{\alpha+\beta}{2}\right) = \frac{1}{3}$$

$$\Rightarrow \sin 2\alpha + \cos 2\theta = \sin(\alpha + \beta) + \cos(\alpha + \beta)$$

$$= \frac{\frac{2}{3}}{1 + \frac{1}{9}} + \frac{1 - \frac{1}{9}}{1 + \frac{1}{9}}$$

$$= \frac{6}{10} + \frac{8}{10} = \frac{7}{5}$$

78. If the lengths of the sides of a triangle are decided by the three throws of a single fair die, then the probability that the triangle is of maximum area given that it is an isosceles triangle, is

(1\*)  $\frac{1}{27}$

(2)  $\frac{1}{26}$

(3)  $\frac{1}{21}$

(4)  $\frac{1}{15}$

Sol. fav. ease all sides (6, 6, 6)

Total case by  $a + b > c$  {(1, 1, 1) (2, 2, 1), (2, 2, 2), (2, 2, 3) (3, 3, 1)..... (3, 3, 5) (4, 4, 1) ..... (4, 4, 6) (5, 5, 1) ..... (5, 5, 6) (6, 6, 1)..... (6, 6, 6)}

$$= 27$$

$$\text{Probability} = \frac{1}{27}$$

79. If the distance between the foci of an ellipse is half the length of its latus rectum, then the eccentricity of the ellipse is

(1)  $\frac{2\sqrt{2}-1}{2}$

(2)  $\frac{1}{2}$

(3\*)  $\sqrt{2}-1$

(4)  $\frac{\sqrt{2}-1}{2}$



**Sol.**  $2ae = \frac{b^2}{a} \Rightarrow 2a^2e = b^2 = a^2(1 - e^2)$

$\Rightarrow 2e = 1 - e^2$

$\Rightarrow (e + 1)^2 = 2$

$\Rightarrow e = \sqrt{2} - 1$

**80.** If the incentre of an equilateral triangle is (1, 1) and the equation of its one side is  $3x + 4y + 3 = 0$ , then the equation of the circumcircle of this triangle is

(1\*)  $x^2 + y^2 - 2x - 2y - 14 = 0$

(2)  $x^2 + y^2 - 2x - 2y - 7 = 0$

(3)  $x^2 + y^2 - 2x - 2y + 2 = 0$

(4)  $x^2 + y^2 - 2x - 2y - 2 = 0$

**Sol.** Let radius is r

$\Rightarrow \frac{r}{2} = \frac{10}{5} \Rightarrow r = 4$

So circle is

$(x - 1)^2 + (y - 1)^2 = 16$

$\Rightarrow x^2 + y^2 - 2x - 2y - 14 = 0$

**81.** If in a regular polygon the number of diagonals is 54, then the number of sides of this polygon is

(1) 6

(2) 9

(3) 10

(4\*) 12

**Sol.** Number of diagonal = 54

$\frac{n(n-3)}{2} = 54$

$n^2 - 3n - 108 = 0$

$\Rightarrow n = 12$

**82.** If A is a  $3 \times 3$  matrix such that  $|5 \cdot \text{adj } A| = 5$ , then  $|A|$  is equal to

(1\*)  $\pm \frac{1}{5}$

(2)  $\pm 1$

(3)  $\pm 5$

(4)  $\pm \frac{1}{25}$

**Sol.**  $125 |A|^2 = 5$

$|A| = \pm \frac{1}{5}$

**83.** A plane containing the point (3, 2, 0) and the line  $\frac{x-1}{1} = \frac{y-2}{5} = \frac{z-3}{4}$  also contains the point

(1\*) (0, 7, 10)

(2) (0, 3, 1)

(3) (0, 7, -10)

(4) (0, -3, 1)

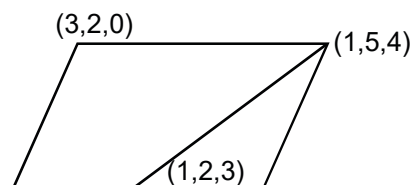

**Sol.**

equation of plane

$15x - 11y + 10z = 23$

84. The equation of a normal to the curve  $\sin y = x \sin\left(\frac{\pi}{3} + y\right)$  at  $x = 0$ , is

- (1)  $2x - \sqrt{3}y = 0$       (2)  $2y + \sqrt{3}x = 0$       (3\*)  $2x + \sqrt{3}y = 0$       (4)  $2y - \sqrt{3}x = 0$

Sol.  $\therefore \sin y = x \sin\left(\frac{\pi}{3} + y\right)$

at  $x = 0, y = 0$

diff. with respect to  $x$

$$\Rightarrow \cos y \frac{dy}{dx} = \sin\left(\frac{\pi}{3} + y\right) + x \cos\left(\frac{\pi}{3} + y\right) \frac{dy}{dx}$$

$$\text{at } (0,0) \frac{dy}{dx} = \frac{\sqrt{3}}{2}$$

$$\Rightarrow \text{Equation of normal is } y - 0 = -\frac{2}{\sqrt{3}}(x - 0)$$

$$\Rightarrow 2x + \sqrt{3}y = 0$$

85. The solution of the differential equation  $ydx - (x + 2y^2) dy = 0$  is  $x = f(y)$ . If  $f(-1) = 1$ , then  $f(1)$  is equal to

- (1\*) 3      (2) 2      (3) 1      (4) 4

Sol.  $\frac{ydx - xdy}{y^2} = 2dy$

$$d\left(\frac{x}{y}\right) = 2dy$$

$$\frac{x}{y} = 2y + c$$

$$\Rightarrow c = 1$$

$$\Rightarrow \frac{x}{y} = 2y + 1$$

$$\text{put } y = 1$$

$$f(1) = 3$$

86. Consider the following statements:

P : Suman is brilliant

Q : Suman is rich

R : Suman is honest

The negation of the statement, "Suman is brilliant and dishonest if and only if Suman is rich" can be equivalently expressed as

- (1)  $\sim Q \leftrightarrow \sim P \vee R$       (2)  $\sim Q \leftrightarrow P \vee \sim R$       (3\*)  $\sim Q \leftrightarrow P \wedge \sim R$       (4)  $\sim Q \leftrightarrow \sim P \wedge R$

Sol. Given statement is equal to  $(p \wedge \sim R) \leftrightarrow Q$

Negation of the above statement is  $\sim Q \leftrightarrow (p \wedge \sim R)$

$$\sim Q \leftrightarrow p \wedge \sim R$$

87. Let  $f : \mathbb{R} \rightarrow \mathbb{R}$  be a function such that  $f(2 - x) = f(2 + x)$  and  $f(4 - x) = f(4 + x)$ , for all  $x \in \mathbb{R}$  and

$$\int_0^2 f(x) dx = 5. \text{ Then the value of } \int_{10}^{50} f(x) dx \text{ is}$$

- (1) 80      (2) 125      (3\*) 100      (4) 200

**Sol.** Put  $x = 2 + x$   
 $f(-x) = f(4 + x) = f(4 - x)$   
 $\Rightarrow f(x) = f(x + 4)$   
 Hence period is 4

$$\int_{10}^{50} f(x)dx = 10 \int_{10}^{14} f(x)dx$$

$$= 10[5 + 5]$$

$$= 100$$

**88.** From the top of a 64 metres high tower, a stone is thrown upwards vertically with the velocity of 48 m/s. The greatest height (in metres) attained by the stone, assuming the value of the gravitational acceleration  $g = 32 \text{ m/s}^2$ , is

- (1) 112                      (2) 88                      (3) 128                      (4\*) 100

**Sol.** At maximum height  $v = 0$   
 Now  $v^2 = u^2 - 2gh$   
 $\Rightarrow 0 = (48)^2 - 2(32)h$   
 $\Rightarrow h = 36$   
 Maximum height =  $36 + 64 = 100 \text{ m}$

**89.** If  $\begin{vmatrix} x^2 + x & x + 1 & x - 2 \\ 2x^2 + 3x - 1 & 3x & 3x - 3 \\ x^2 + 2x + 3 & 2x - 1 & 2x - 1 \end{vmatrix} = ax - 12$ , then 'a' is equal to

- (1) -24                      (2\*) 24                      (3) 12                      (4) -12

**Sol.** Put  $x = -1$   
 $\begin{vmatrix} 0 & 0 & -3 \\ -2 & -3 & 0 \\ 2 & -3 & -3 \end{vmatrix} = -a - 12$   
 $\Rightarrow a = 24$

**90.** If  $\int \frac{\log(t + \sqrt{1+t^2})}{\sqrt{1+t^2}} dt = \frac{1}{2} (g(t))^2 + C$ , where C is a constant, then  $g(2)$  is equal to

- (1)  $\log(2 + \sqrt{5})$                       (2\*)  $2\log(2 + \sqrt{5})$                       (3)  $\frac{1}{2}\log(2 + \sqrt{5})$                       (4)  $\frac{1}{\sqrt{5}}\log(2 + \sqrt{5})$

**Sol.**  $I = \int \frac{\log(t + \sqrt{1+t^2})}{\sqrt{1+t^2}} dt$   
 put  $u = \log(t + \sqrt{1+t^2})$   
 $du = \frac{1}{\sqrt{1+t^2}} dt$   
 $I = \int u du = \frac{u^2}{2} + c$   
 $g(t) = \log(1 + \sqrt{1+t^2})$   
 $g(2) = \log(2 + \sqrt{5})$